

4

3

2

1

NOTES:

- 1. APPLICABLE STANDARDS/SPECIFICATIONS:
ASME Y14.5M-1994, DIMENSIONING AND TOLERANCING
ASME Y14.38-1999, ABBREVIATIONS
- 2. COMPONENT OR ITEM TO BE COMPLIANT WITH THE MOST CURRENT REVISION OF THE RoHS / Wee DIRECTIVE FOR THE REDUCTION OF HAZARDOUS SUBSTANCES AND MATERIALS.
- 3. ALL DIMENSIONS ARE FOR REFERENCE ONLY.
- 4. ITEM INDIVIDUALLY SEALED IN BAG

REV	DATE	EC #	ZONE	DESCRIPTION	DRAWN	CKD
A	2020-05-14			ORIGINATED	NR	JMA
B	2020-09-04	2222		ADDED BAG	NR	

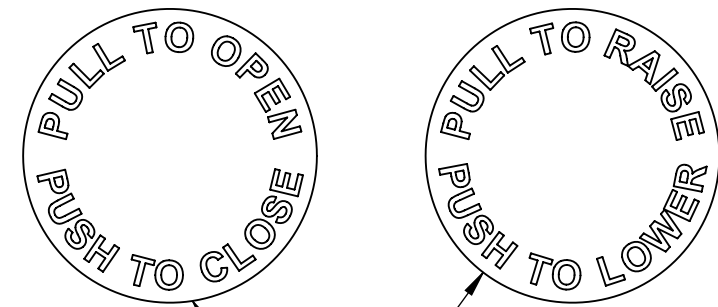
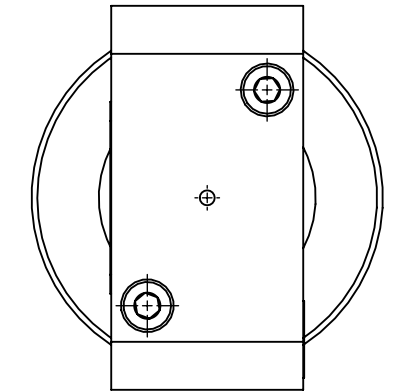
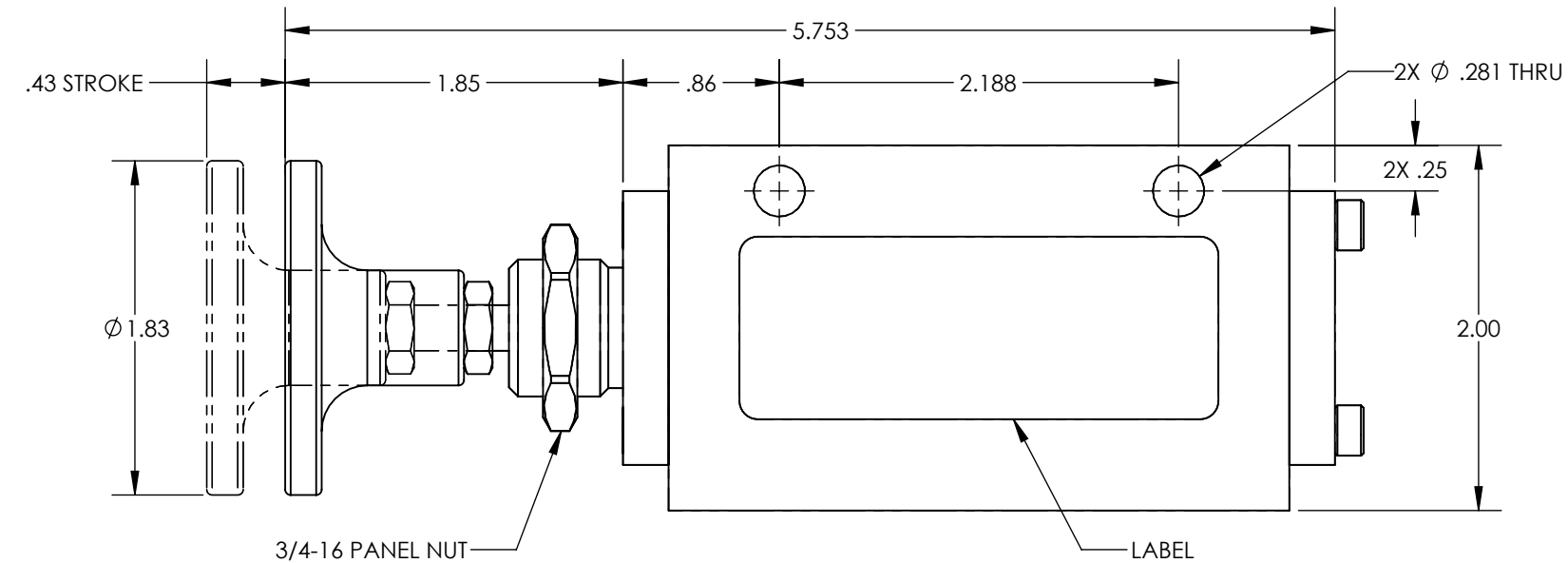
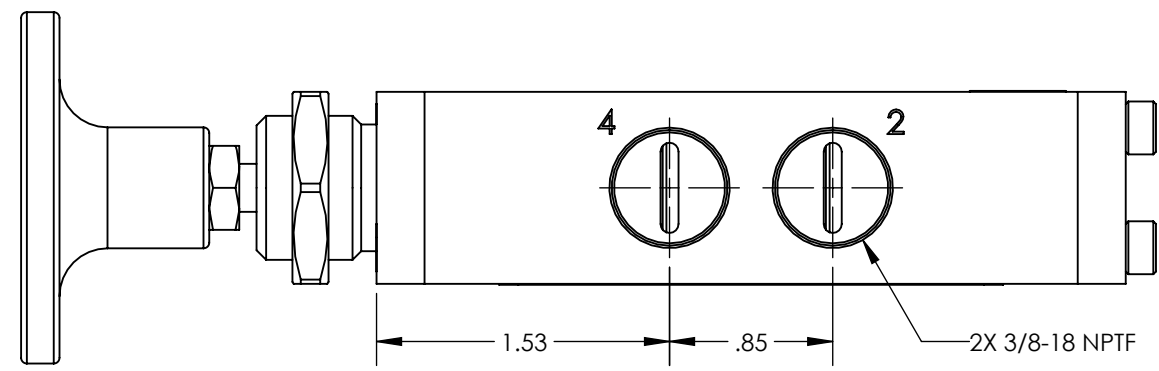

SELF ADHESIVE KNOB LABELS SHIPPED LOOSE WITH VALVE

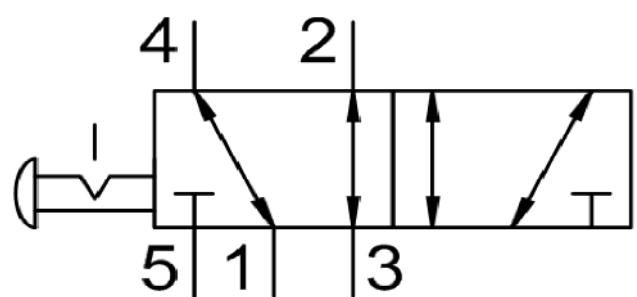
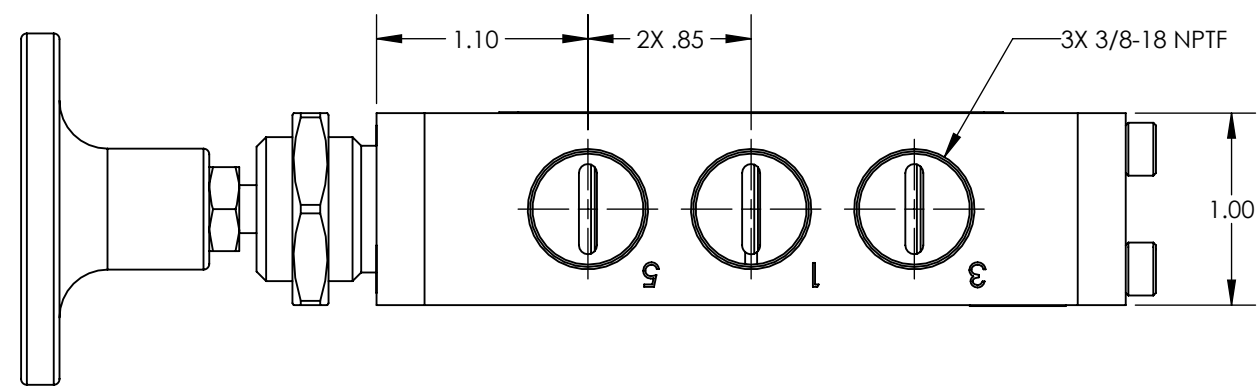

FUNCTION	5/2 PUSH/ PULL WITH KNOB OUT SOFT DETENT
MECHANICAL MATERIALS	ALUMINUM BODY & END CAP
SEALS	LOW TEMP. NITRILE, LOW COMP. SET POLYURETHANE
FASTENERS	STAINLESS STEEL
MTG STYLE	BODY SIDE
ASSY LUBRICATION	HEAVY TRANSPORT SILICONE
FLOW	2.2 Cv
TEMP	-40 TO 180°F
FILTRATION	40 MICRON
SYSTEM LUBRICATION REQ'D	N/A
PRESSURE RANGE	MIN: VAC MAX: 150 psi
LEAK	N/A
ELECTRICAL VOLTAGE	N/A
CURRENT	N/A

CUSTOMER PRINT

NOTE: PART MUST BE CLEAN AND BURR FREE
MFG TOLERANCES UNLESS OTHERWISE NOTED:
ALL UNITS ARE INCHES
(2) DECIMAL PLACES: ±.01
(3) DECIMAL PLACES: ±.005
ANGLES: ±.5°
BREAK ALL EDGES .005/.015 X 45°
MACHINED SURFACES TO BE 63 RMS
CRITICAL CHARACTERISTIC - CONTROL PLAN REQUIRED

CONFIDENTIAL: THIS DRAWING OR ANY PART THEREOF IS PROPRIETARY AND MAY NOT BE REPRODUCED OR COPIED WITHOUT WRITTEN CONSENT OF AIRMAN PRODUCTS

DRAWN BY	NR	DESCRIPTION
DRAWN DATE	2020-05-14	VALVE, .38 NPT, 5-2, VC-PPDET
DRAWING SIZE	B	PART NUMBER
MATERIAL	SEE NOTES	B2400-B40
SCALE	1:1	
SHEET #	1 OF 1	

4

3

2

1

B

B

A

A