

4

3

2

1

REV	DATE	EC #	ZONE	DESCRIPTION	DRAWN	CKD
A	2020-09-28			ORIGINATED	NR	JMA

NOTES:

1. APPLICABLE STANDARDS/SPECIFICATIONS:
ASME Y14.5M-1994, DIMENSIONING AND TOLERANCING
ASME Y14.38-1999, ABBREVIATIONS
2. COMPONENT OR ITEM TO BE COMPLIANT WITH THE MOST CURRENT REVISION OF THE RoHS / Wee DIRECTIVE FOR THE REDUCTION OF HAZARDOUS SUBSTANCES AND MATERIALS.
3. ALL DIMENSIONS ARE FOR REFERENCE ONLY.
4. ITEM INDIVIDUALLY SEALED IN LABELED BAG.
5. ITEM IS RETAIL PACKED QR2-BLK.

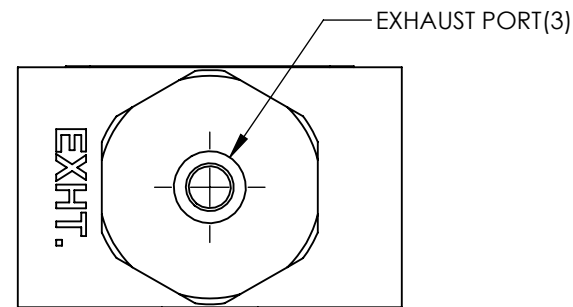
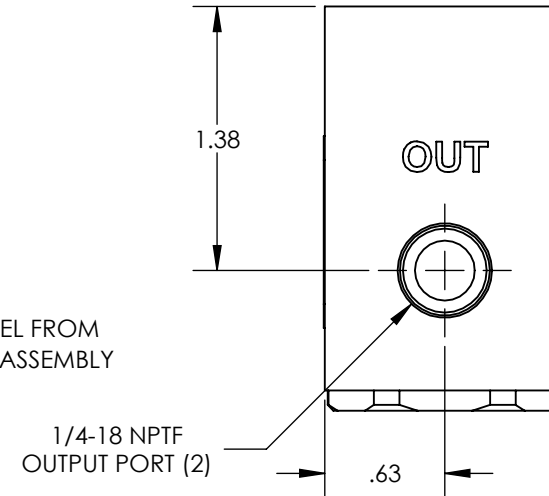
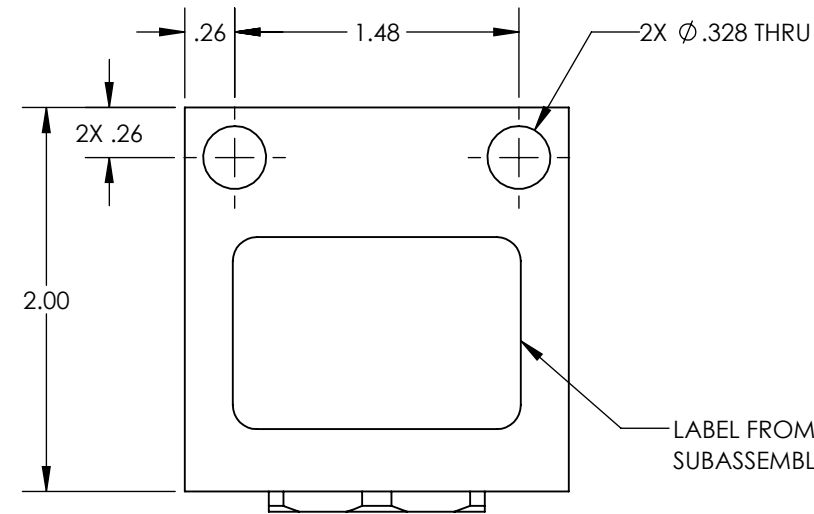
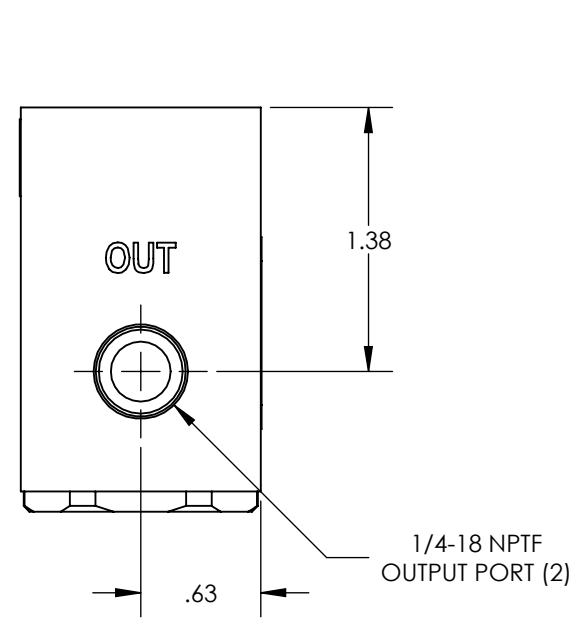
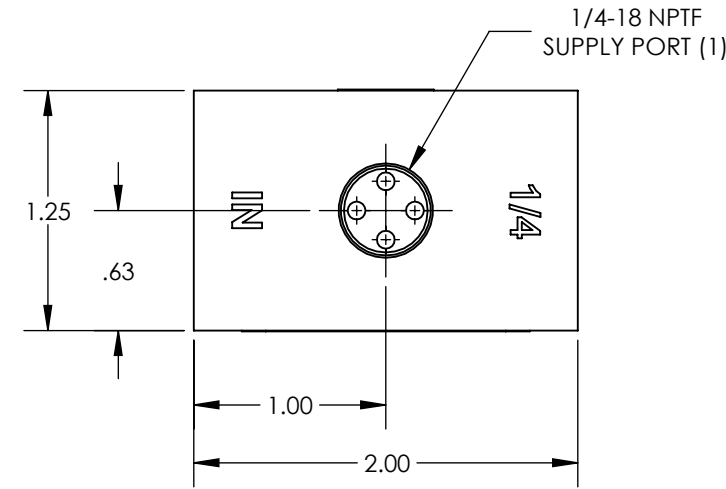

FUNCTION	QUICK EXHAUST
MECHANICAL MATERIALS	ALUMINUM
SEALS	LOW TEMP. NITRILE, LOW COMP. SET POLYURETHANE
FASTENERS	N/A
MTG STYLE	LINE MOUNT OR BODY MOUNT
ASSY LUBRICATION	SILICONE
FLOW	4.25 Cv
TEMP	-40 TO 180°F
FILTRATION	40 MICRON
SYSTEM LUBRICATION REQ'D	N/A
PRESSURE RANGE	MIN: 5 psi MAX: 150 psi (5 psi DIFFERENTIAL REQUIRED TO EXHAUST)
LEAK	< 230 sccm @100 psi
ELECTRICAL VOLTAGE	N/A
CURRENT	N/A

CUSTOMER PRINT

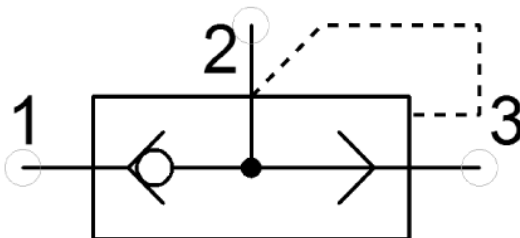

NOTE: PART MUST BE CLEAN AND BURR FREE
MFG TOLERANCES UNLESS OTHERWISE NOTED:
ALL UNITS ARE INCHES
(2) DECIMAL PLACES: ±.01
(3) DECIMAL PLACES: ±.005
ANGLES: ±.5°
BREAK ALL EDGES .005/.015 X 45°
MACHINED SURFACES TO BE 63 RMS
CRITICAL CHARACTERISTIC - CONTROL PLAN REQUIRED

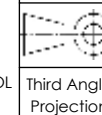

CONFIDENTIAL: THIS DRAWING OR ANY PART THEREOF IS PROPRIETARY AND MAY NOT BE REPRODUCED OR COPIED WITHOUT WRITTEN CONSENT OF AIRMAN PRODUCTS

DRAWN BY	NR	DESCRIPTION
DRAWN DATE	2020-09-28	QUICK EXHAUST .25 NPT
DRAWING SIZE	B	PART NUMBER
MATERIAL	SEE NOTES	B2400-B82
SCALE	1:1	
SHEET #	1 OF 1	

4

3

2

1

B

B

A

A