

4

3

2

1

NOTES:

- 1. APPLICABLE STANDARDS/SPECIFICATIONS:
ASME Y14.5M-1994, DIMENSIONING AND TOLERANCING
ASME Y14.38-1999, ABBREVIATIONS
- 2. COMPONENT OR ITEM TO BE COMPLIANT WITH THE MOST CURRENT REVISION OF THE RoHS / Wee DIRECTIVE FOR THE REDUCTION OF HAZARDOUS SUBSTANCES AND MATERIALS.
- 3. ALL DIMENSIONS ARE FOR REFERENCE ONLY
- 4. SPRING LOAD TO MATCH MGM P/N 5005012

REV	DATE	EC #	ZONE	DESCRIPTION	DRAWN	CKD
A	2005-07-14			ORIGINATED	DC	
B	2005-08-31			11.12 WAS 10.62	DC	
B1	2012-05-24			DATE STAMP, LETTER CODE	AJ	
C	2022-09-27	2320		REMOVED EPOXY	CED	
D	2022-12-14	2321		REDRAWN IN SOLIDWORKS, ADDED 1900-620	NR	CED

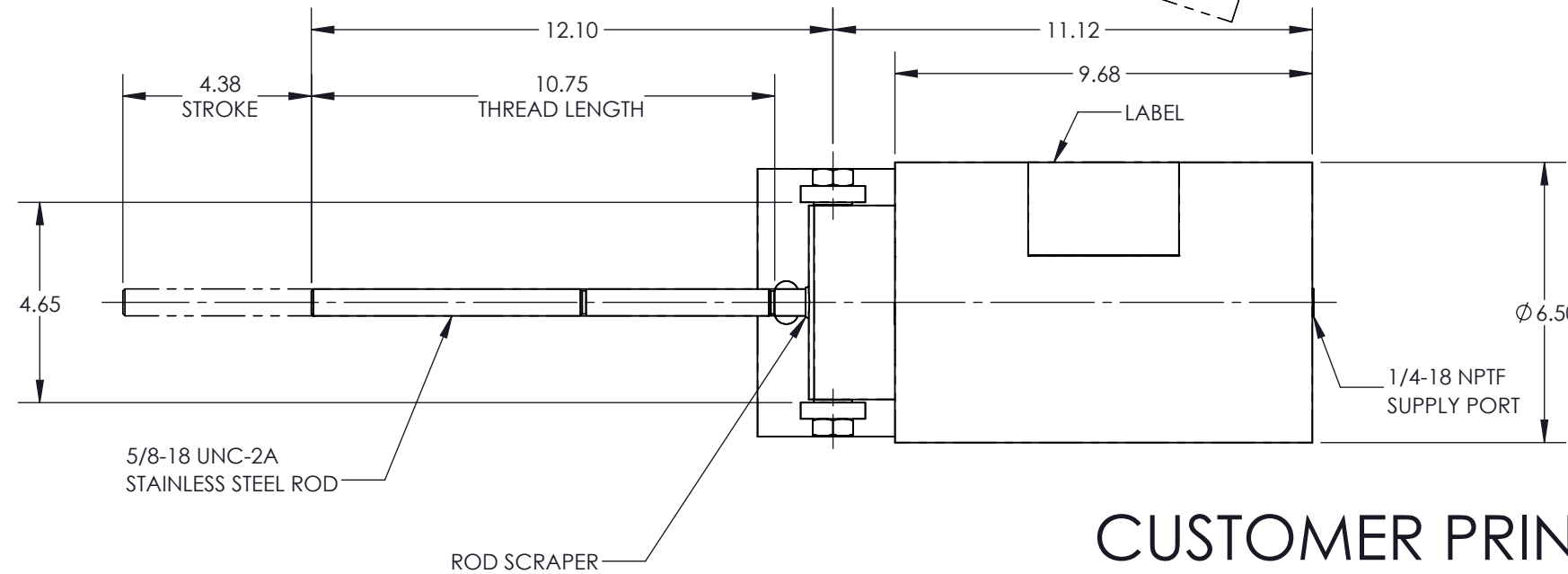
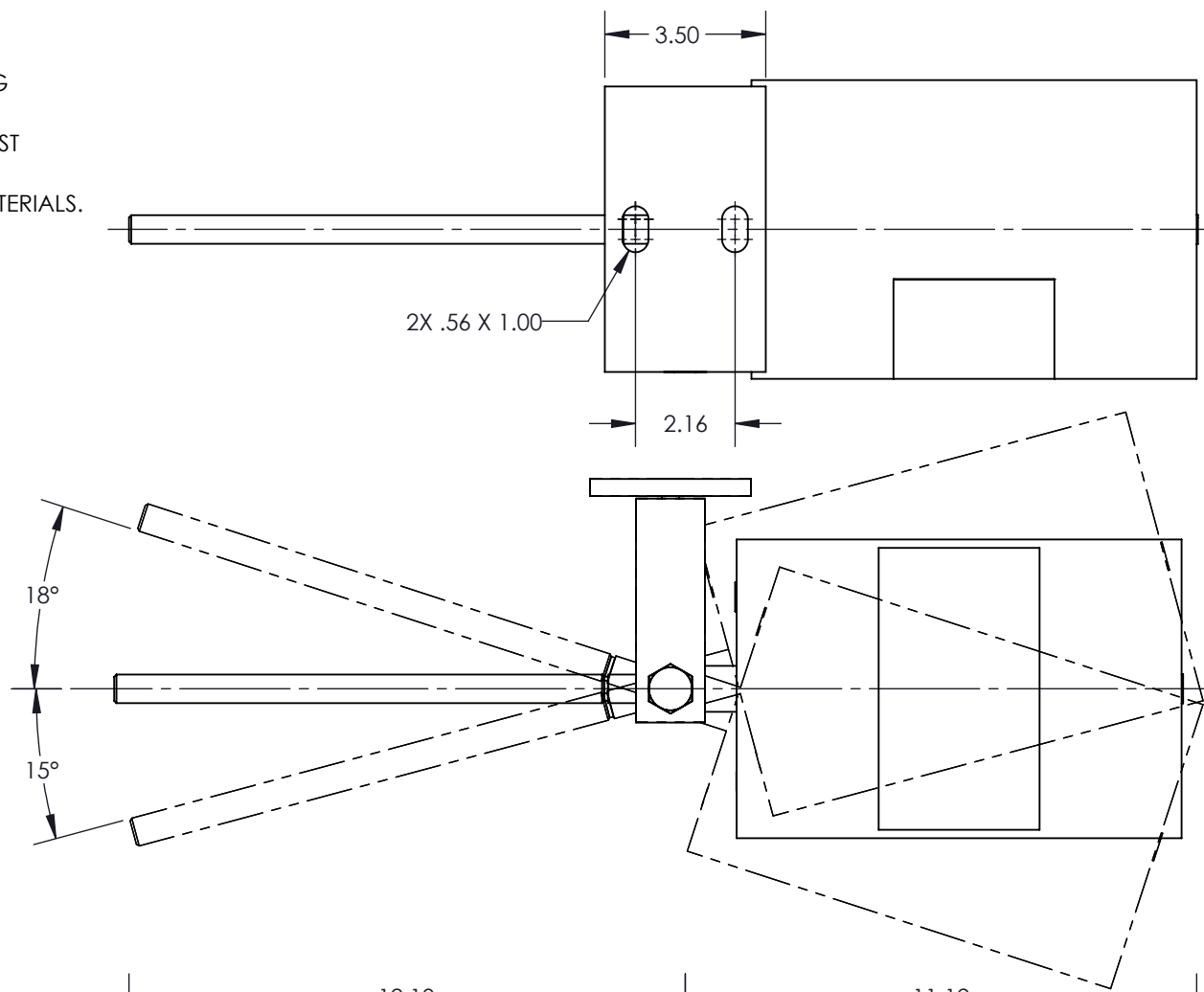
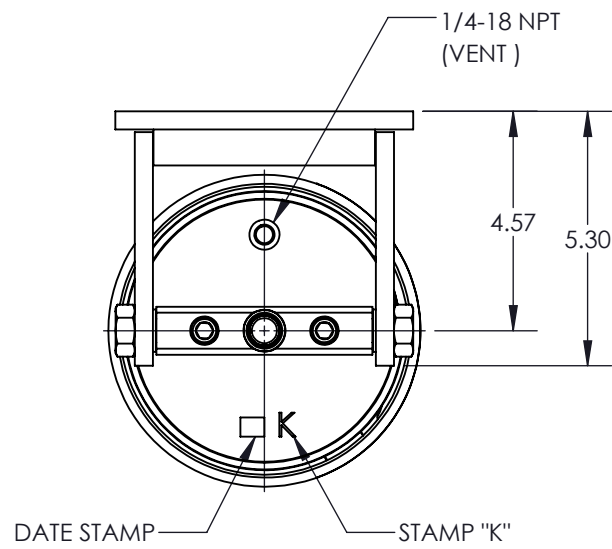

FUNCTION	PNEUMATIC CYLINDER TAIL GATE SINGLE ACTING
MECHANICAL MATERIALS	1/4" WALL ALUMINUM TUBE, STEEL CONSTRUCTION TRUNNION BRACKET WITH OIL LIGHT BUSHINGS AND STAINLESS STEEL PINS, OIL LIGHT ROD BEARING
SEALS	LOW TEMP. NITRILE, LOW COMP. SET POLYURETHANE
FASTENERS	STAINLESS STEEL
MTG STYLE	SIDE MOUNTING BRACKET
ASSY LUBRICATION	HEAVY TRANSPORT SILICONE
FLOW	N/A
TEMP	-40 TO 180°F
FILTRATION	40 MICRON RECOMMENDED
SYSTEM LUBRICATION REQ'D	N/A
PRESSURE RANGE	MIN: 95 PSI MAX: 150 psi PILOT: NA
LEAK	50 sccm MAX @ 120 psi
ELECTRICAL VOLTAGE	N/A
CURRENT	N/A

CUSTOMER PRINT

NOTE: PART MUST BE CLEAN AND BURR FREE
MFG TOLERANCES UNLESS OTHERWISE NOTED:
ALL UNITS ARE INCHES
(2) DECIMAL PLACES: ±.01
(3) DECIMAL PLACES: ±.005
ANGLES: ±.5°
BREAK ALL EDGES .005/.015 X 45°
MACHINED SURFACES TO BE 63 RMS
CRITICAL CHARACTERISTIC - CONTROL PLAN REQUIRED

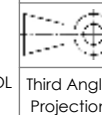

CONFIDENTIAL: THIS DRAWING OR ANY PART THEREOF IS PROPRIETARY AND MAY NOT BE REPRODUCED OR COPIED WITHOUT WRITTEN CONSENT OF AIRMAN PRODUCTS

DRAWN BY	DC	DESCRIPTION
DRAWN DATE	2005-07-14	CYL, TAIL-A-GATER, 6.00 X 4.38, SIDE BRK
DRAWING SIZE	B	PART NUMBER
MATERIAL	SEE NOTES	B3000-301
SCALE	1:4	
SHEET #	1 OF 1	

4

3

2

1

B

B

A

A