

4

3

2

1

NOTES:

- 1. APPLICABLE STANDARDS/SPECIFICATIONS:
ASME Y14.5M-1994, DIMENSIONING AND TOLERANCING
ASME Y14.38-1999, ABBREVIATIONS
- 2. COMPONENT OR ITEM TO BE COMPLIANT WITH THE MOST CURRENT REVISION OF THE RoHS / Wee DIRECTIVE FOR THE REDUCTION OF HAZARDOUS SUBSTANCES AND MATERIALS.
- 3.
- 4. TABLE PRINT: USE CHART ASSOCIATED WITH AIRMAN ASSEMBLY PART NUMBER. SUFFIXES (EXAMPLES -CLR AND -BLK) ATTACHED TO THE END OF THE AIRMAN PART NUMBER WILL INDICATE THE ANODIZATION COLOR (IF APPLICABLE)
- 5. ITEM INDIVIDUALLY SEALED IN BAG

REV	DATE	EC #	ZONE	DESCRIPTION	DRAWN	CKD
A	2019-11-16			ORIGINATED	NR	CED
B	2020-09-08	2222		ADDED BAG	NR	

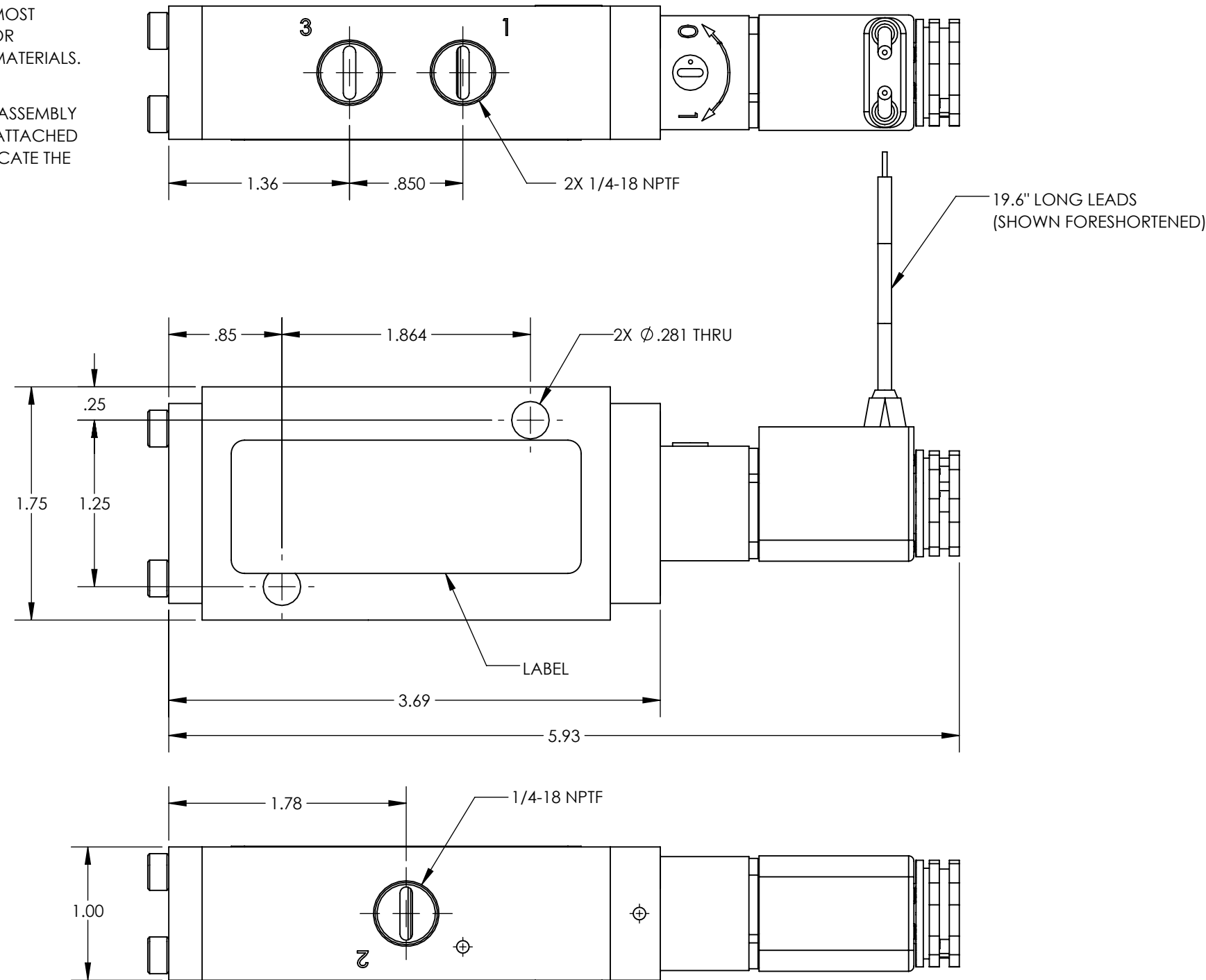

FUNCTION	3/2 INTERNAL SUPPLIED SOLENOID SPRING RESET
MECHANICAL MATERIALS	ALUMINUM BODY & END CAP
SEALS	LOW TEMP. NITRILE, LOW COMP. SET POLYURETHANE
FASTENERS	STAINLESS STEEL
MTG STYLE	BODY SIDE
ASSY LUBRICATION	HEAVY TRANSPORT SILICONE
FLOW	1.5 Cv
TEMP	-40 TO 180°F
FILTRATION	40 MICRON REQUIRED
SYSTEM LUBRICATION REQ'D	N/A
PRESSURE RANGE	MIN: 55 psi MAX: 150 psi PILOT: INTERNAL
LEAK	N/A
ELECTRICAL VOLTAGE	12 VDC
CURRENT	5 WATT WITH FLYING LEADS

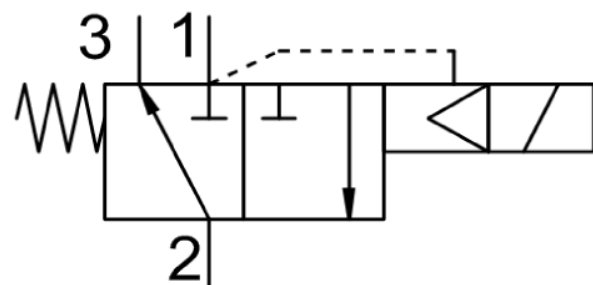

CUSTOMER PRINT

AIRman PART NUMBER CHART	
AIRman PART NUMBER	ANODIZATION COLOR
V2516N0523-DAL	NON-ANODIZED
V2516N0523-DAL-BLK	BLACK-ANODIZED
V2516N0523-DAL-CLR	CLEAR-ANODIZED

NOTE: PART MUST BE CLEAN AND BURR FREE
MFG TOLERANCES UNLESS OTHERWISE NOTED:
ALL UNITS ARE INCHES
(2) DECIMAL PLACES: ±.01
(3) DECIMAL PLACES: ±.005
ANGLES: ±.5°
BREAK ALL EDGES .005/.015 X 45°
MACHINED SURFACES TO BE 63 RMS
CRITICAL CHARACTERISTIC - CONTROL PLAN REQUIRED

AIRman PRODUCTS

CONFIDENTIAL: THIS DRAWING OR ANY PART THEREOF IS PROPRIETARY AND MAY NOT BE REPRODUCED OR COPIED WITHOUT WRITTEN CONSENT OF AIRMAN PRODUCTS

DRAWN BY	NR	DESCRIPTION
DRAWN DATE	2019-11-16	VALVE, .25 NPT, 3-2, SOL-SR, 12DC
DRAWING SIZE	B	PART NUMBER
MATERIAL	SEE NOTES	V2516N0523-DAL
SCALE	1:1	
SHEET #	1 OF 1	

4

3

2

1