

4

3

2

1

REV	DATE	EC #	ZONE	DESCRIPTION	DRAWN	CKD
A	2020-09-15			ORIGINATED	NR	JMA
A1	2020-10-06			CHANGED LAYOUT OF DATE STAMP AND LABEL	NR	JMA

NOTES:

1. APPLICABLE STANDARDS/SPECIFICATIONS:
ASME Y14.5M-1994, DIMENSIONING AND TOLERANCING
ASME Y14.38-1999, ABBREVIATIONS
2. COMPONENT OR ITEM TO BE COMPLIANT WITH THE MOST CURRENT REVISION OF THE RoHS / Wee DIRECTIVE FOR THE REDUCTION OF HAZARDOUS SUBSTANCES AND MATERIALS.
3. ALL DIMENSIONS ARE FOR REFERENCE ONLY.
4. TABLE PRINT: USE BOM ASSOCIATED WITH AIRMAN ASSEMBLY PART NUMBER. SUFFIXES (EXAMPLES -CLR AND -BLK) ATTACHED TO THE END OF THE AIRMAN PART NUMBER WILL INDICATE THE COLUMN TO USE, NO SUFFIX USE THE QTY COLUMN.
5. ITEM INDIVIDUALLY SEAL IN BAG

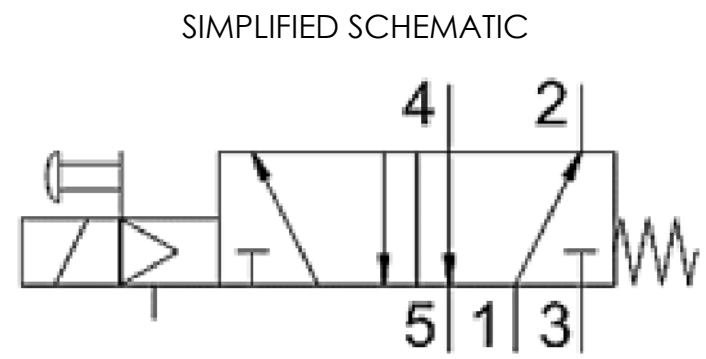
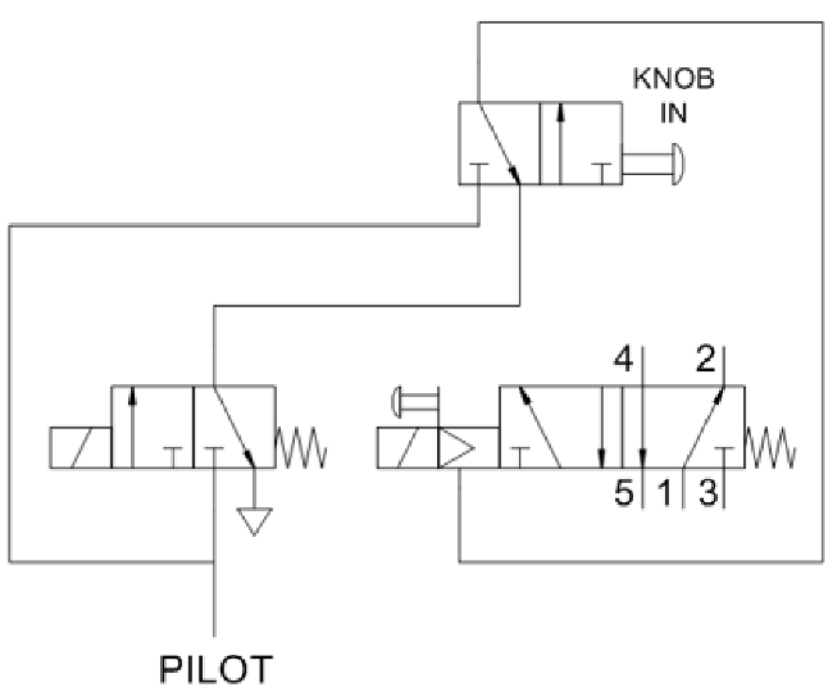
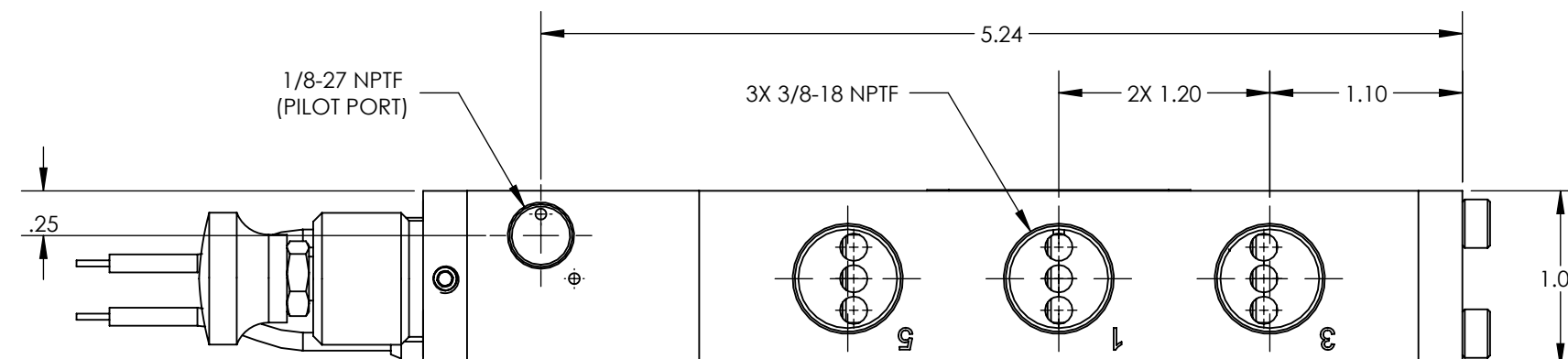
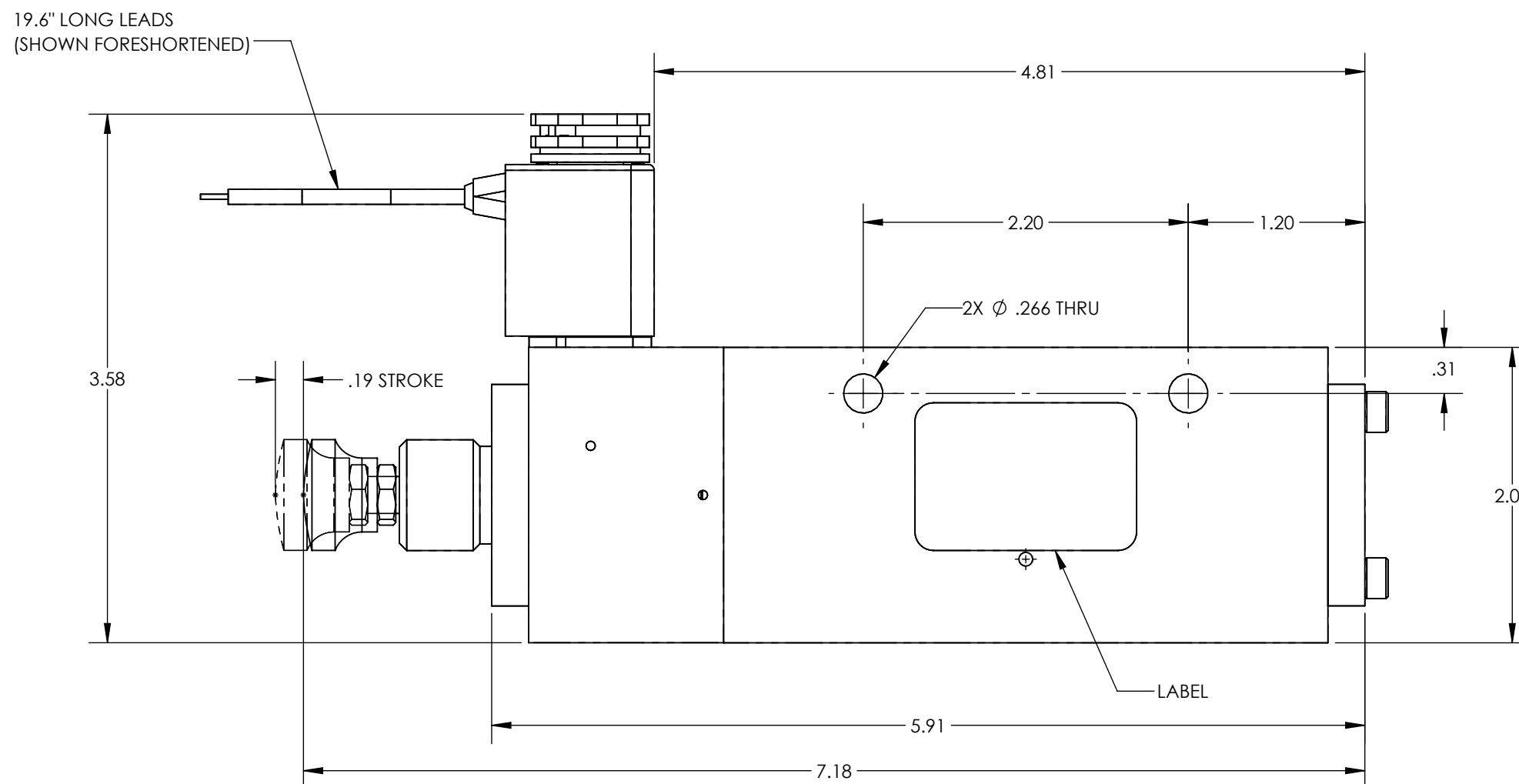
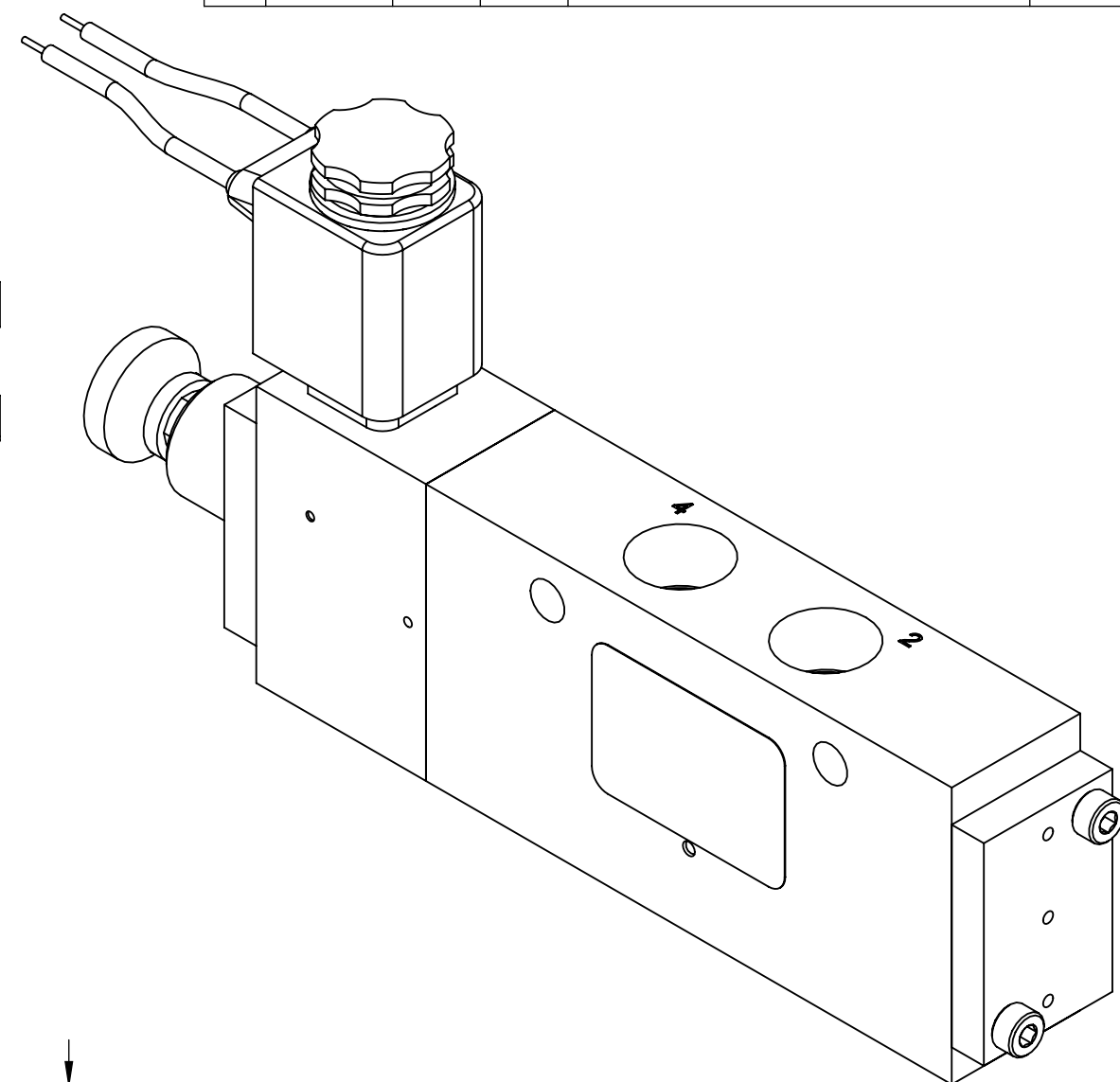
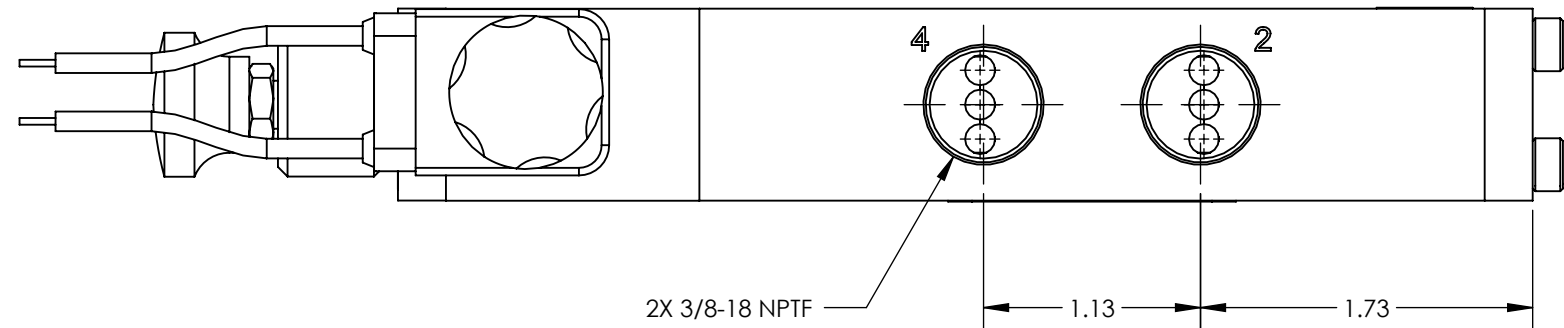

AIRman PART NUMBER CHART	
AIRman PART NUMBER	ANODIZATION COLOR
V38505E912-DAL	NON-ANODIZED
V38505E912-DAL-BLK	BLACK-ANODIZED
V38505E912-DAL-CLR	CLEAR-ANODIZED

CUSTOMER PRINT

NOTE: PART MUST BE CLEAN AND BURR FREE
MFG TOLERANCES UNLESS OTHERWISE NOTED:
ALL UNITS ARE INCHES
(2) DECIMAL PLACES: ±.01
(3) DECIMAL PLACES: ±.005
ANGLES: ±.5°
BREAK ALL EDGES .005/.015 X 45°
MACHINED SURFACES TO BE 63 RMS
CRITICAL CHARACTERISTIC - CONTROL PLAN REQUIRED

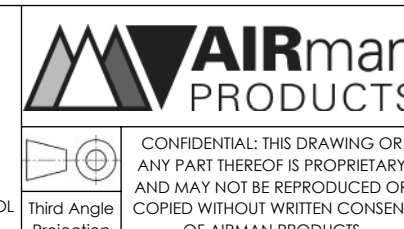

DRAWN BY	NR	DESCRIPTION
DRAWN DATE	2020-09-15	VALVE, .38 NPT, 5-2, SR-PPSOL, 12DC
DRAWING SIZE	C	
MATERIAL	SEE NOTES	PART NUMBER
SCALE	1:1	
SHEET #	1 OF 1	V38505E912-DAL

FUNCTION	5/2 SOL. / SPRING RESET WITH AIR OPERATED MANUAL OVERRIDE; EXTERNALLY SUPPLIED
MECHANICAL MATERIALS	ALUMINUM BODY & END CAPS
SEALS	LOW TEMP. NITRILE; LOW COMP. SET POLYURETHANE
FASTENERS	STAINLESS STEEL
MTG STYLE	BODY SIDE MOUNT THRU
ASSY LUBRICATION	HEAVY TRANSPORT SILICONE
FLOW	2.2 Cv
TEMP	-40 TO 180°F
FILTRATION	40 MICRON REQUIRED
SYSTEM LUBRICATION REQ'D	N/A
PRESSURE RANGE	MIN: 55 psi MAX: 150 psi
LEAK	N/A
ELECTRICAL VOLTAGE	12 VDC
CURRENT	5 WATTS FLYING LEADS

4

3

2

1