

4

3

2

1

NOTES:

- 1. APPLICABLE STANDARDS/SPECIFICATIONS:  
ASME Y14.5M-1994, DIMENSIONING AND TOLERANCING  
ASME Y14.38-1999, ABBREVIATIONS
- 2. COMPONENT OR ITEM TO BE COMPLIANT WITH THE MOST CURRENT REVISION OF THE RoHS / Wee DIRECTIVE FOR THE REDUCTION OF HAZARDOUS SUBSTANCES AND MATERIALS.
- 3. ALL DIMENSIONS ARE FOR REFERENCE ONLY.

REV	DATE	EC #	ZONE	DESCRIPTION	DRAWN	CKD
A	2004-12-06			ORIGINATED	DC	
A1	2007-09-11			ADDED NOTE	JB	
A2	2016-09-29	1567		REVISE REGULATOR	AJ	
B	2021-03-05	2241		CHANGED SOLENOID VALVE SUPPLIER AND RESTRUCTURED BOM	NR	CED

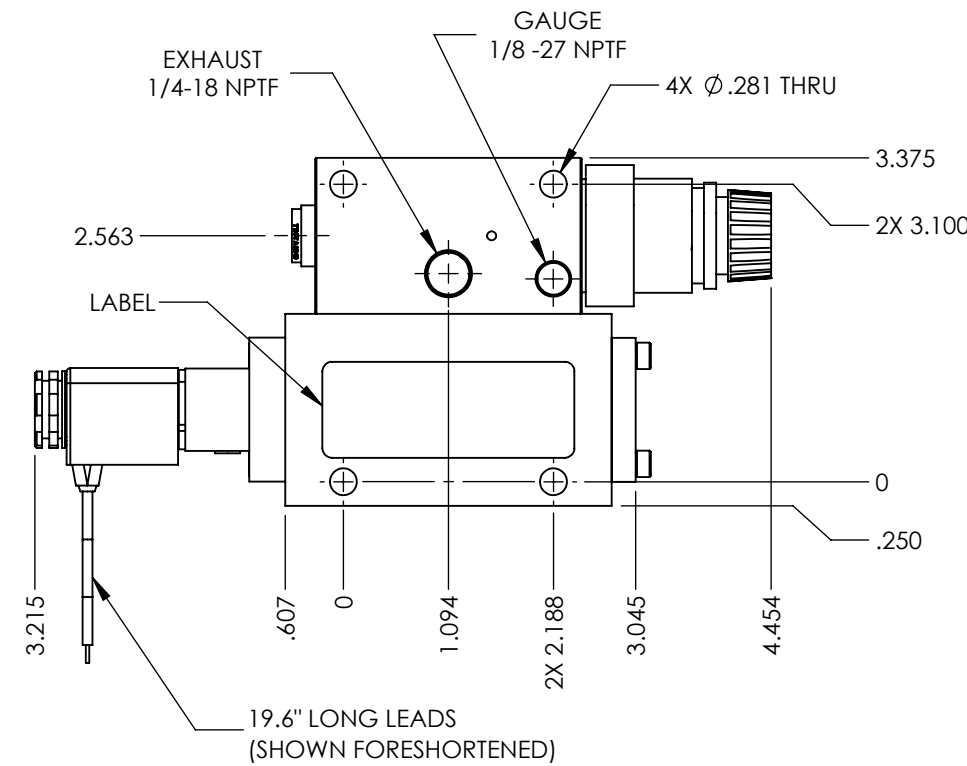
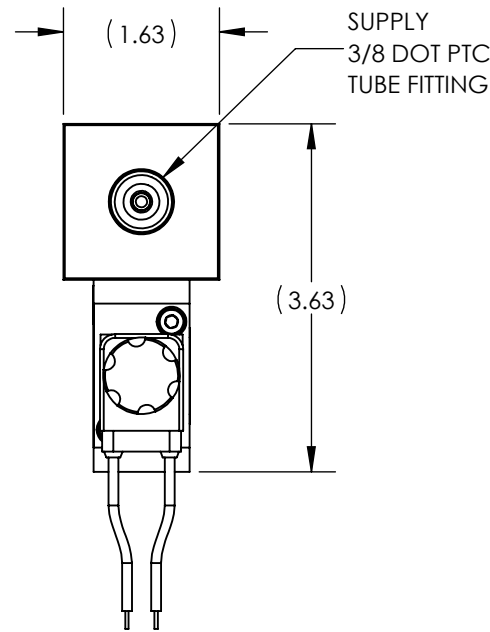
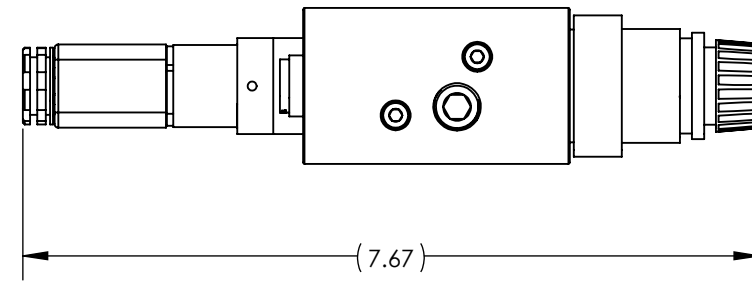

GAUGE SHIPPED SEPARATELY WITH VALVE ASSEMBLY

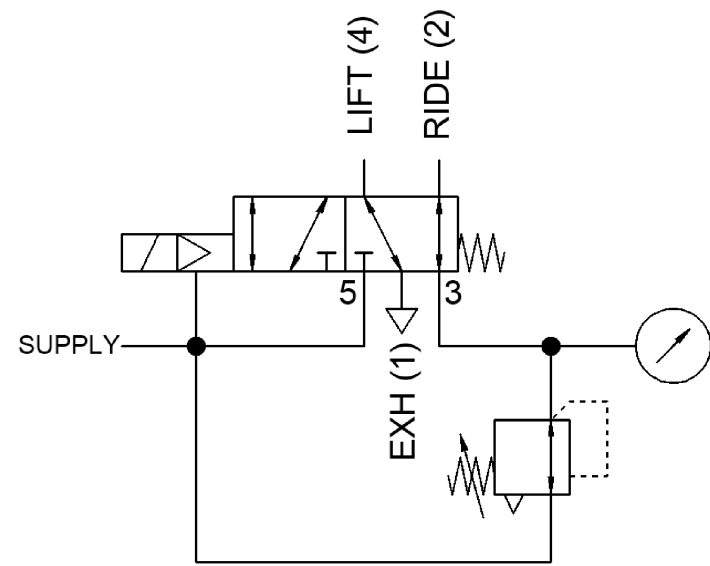
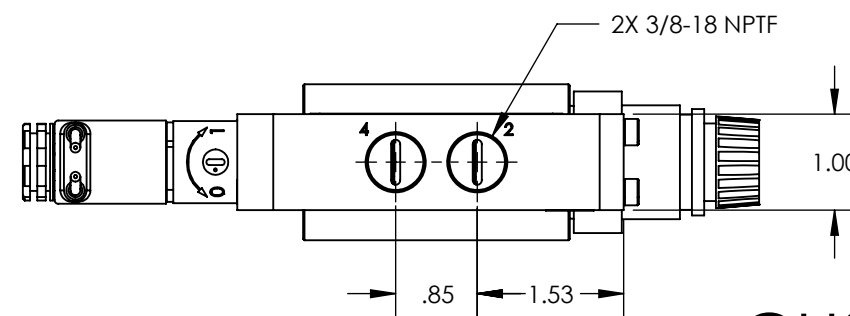
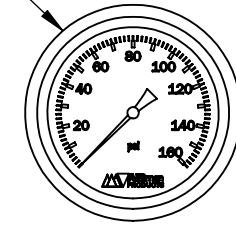

FUNCTION	VALVE, SOLENOID CONTROLLED LIFT AXLE, NORMALLY DOWN
MECHANICAL MATERIALS	ALUMINUM BODY & NYLON KNOB
SEALS	LOW TEMP. NITRILE, LOW COMP. SET POLYURETHANE
FASTENERS	STAINLESS STEEL
MTG STYLE	BODY SIDE
ASSY LUBRICATION	HEAVY TRANSPORT SILICONE
FLOW	N/A
TEMP	-40 TO 180°F
FILTRATION	40 MICRON RECOMMENDED
SYSTEM LUBRICATION REQ'D	N/A
PRESSURE RANGE	MIN: 60 PSI MAX: 150 PSI
LEAK	MAX: 30 SCCM
ELECTRICAL VOLTAGE	N/A
CURRENT	5 WATT WITH FLYING LEADS

CUSTOMER PRINT

NOTE: PART MUST BE CLEAN AND BURR FREE  
MFG TOLERANCES UNLESS OTHERWISE NOTED:  
ALL UNITS ARE INCHES  
(2) DECIMAL PLACES: ±.01  
(3) DECIMAL PLACES: ±.005  
ANGLES: ±.5°  
BREAK ALL EDGES .005/.015 X 45°  
MACHINED SURFACES TO BE 63 RMS  
CRITICAL CHARACTERISTIC - CONTROL PLAN REQUIRED

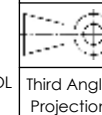

CONFIDENTIAL: THIS DRAWING OR ANY PART THEREOF IS PROPRIETARY AND MAY NOT BE REPRODUCED OR COPIED WITHOUT WRITTEN CONSENT OF AIRMAN PRODUCTS

DRAWN BY	NR	DESCRIPTION
DRAWN DATE	2021-03-05	VALVE AND WITH GAUGE, SOL CTRL LIFT AXLE
DRAWING SIZE	B	PART NUMBER
MATERIAL	SEE NOTES	B2400-575-ANDG
SCALE	1:2	
SHEET #	1 OF 1	

4

3

2

1

B

B

A

A