

BOX DIMENSIONS ARE:  
 HEIGHT = 4.25"  
 LENGTH = 11.63"  
 WIDTH = 9.41"

ECN	REV	CHANGE	DATE	BY
	A	ORIGINATED	5/29/07	DC
	A1	UPDATE TO SUBASSY	8/7/19	JMA

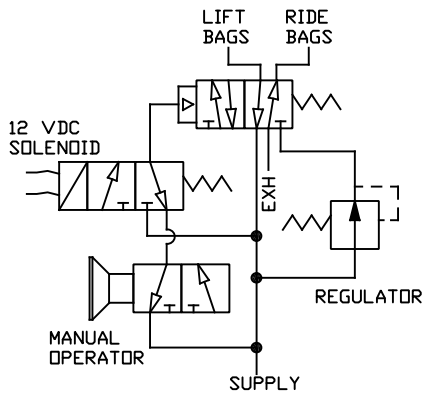
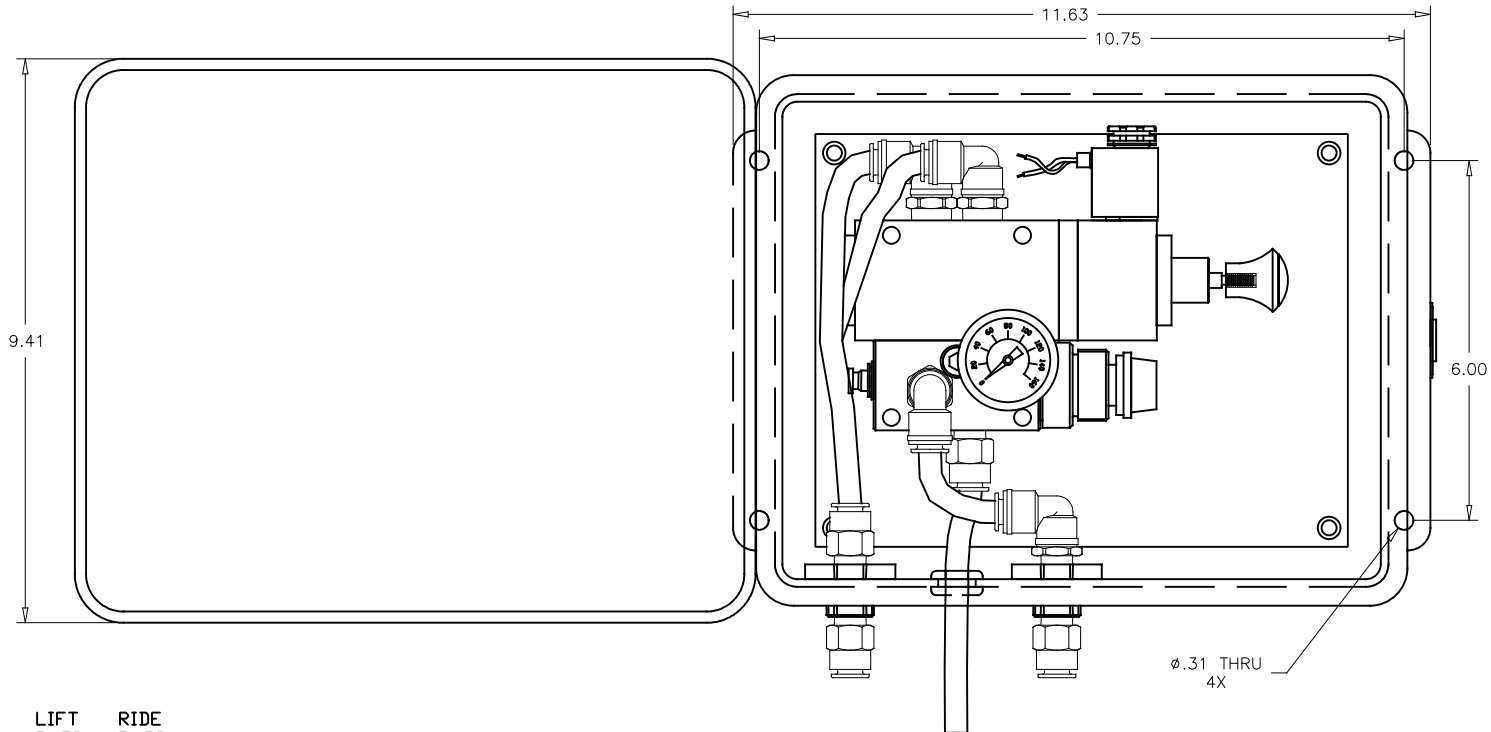

# ACE

## Air Control Enclosures

Axle Normally Up  
 Solenoid/Manual Operated Down  
 Regulated Ride Pressure with Gauge

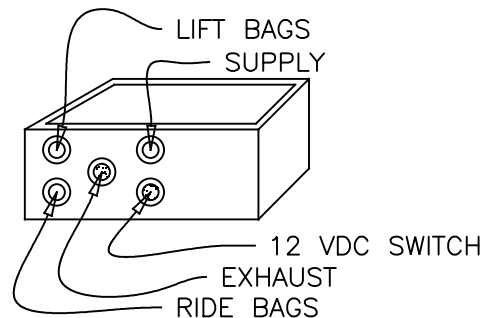

DO NOT SCALE PRINT

USED ON:
NOTE: PART MUST BE CLEAN AND BURR FREE MFG TOLERANCES UNLESS OTHERWISE NOTED: TOLERANCES: (2) DECIMAL PLACES +/- .01 (3) DECIMAL PLACES +/- .005 ANGLES: +/- .5 DEG. BREAK ALL EDGES .005/.015 X 45° MACHINED SURFACES TO BE 63 RMS
DESC 1:

CONFIDENTIAL  
 THIS DRAWING OR ANY PART THEREOF IS  
 PROPRIETARY AND MAY NOT BE REPRODUCED  
 OR COPIED WITHOUT WRITTEN CONSENT OF  
 AIRMAN INC.

DATE	DRAWN	CHECKED	AIRMAN, Inc.	MATERIAL:	PART IDENTIFIER
5/29/07			Creative Pneumatics	STOCK SIZE	B5000-026
NAME	DC		WWW.AIRMANINC.COM	SCALE: 1:1	ANUG
			COPYRIGHT ©1997 AIRMAN INC.	FINISH:	PG. 1 OF 1