

REVISIONS		DATE	APPROVED
ZONE	REV.	DESCRIPTION	

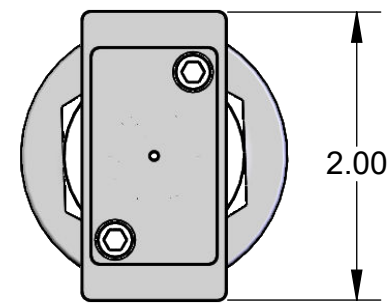

7/8 - 14 PANEL MOUNT THREAD

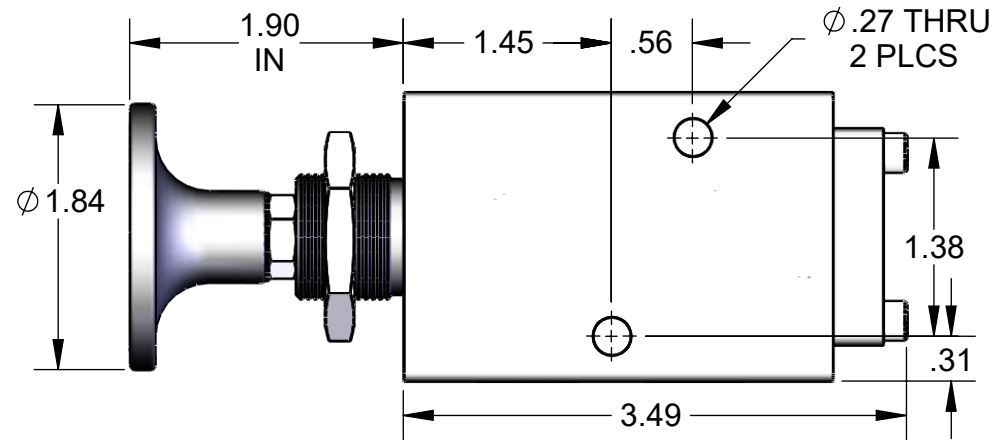
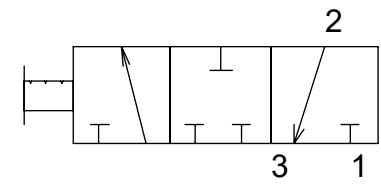
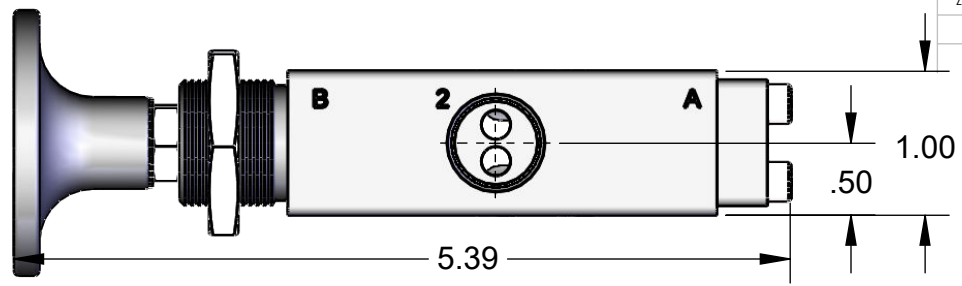
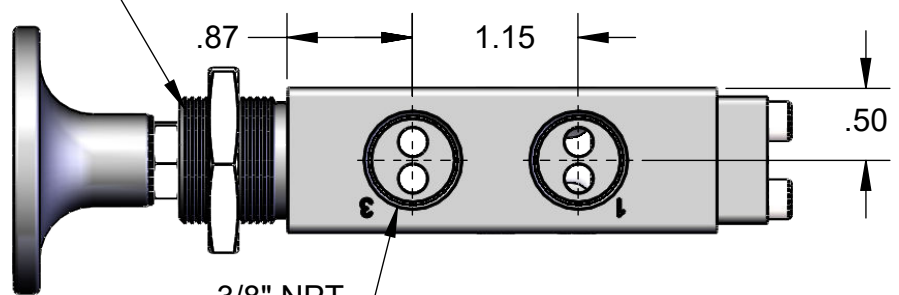

**CONSTRUCTION:**  
 ALUMINUM, STAINLESS FASTENERS,  
 LOW TEMP. URETHANE SEALS.  
 PLASTIC KNOB, STAINLESS JAM NUT.

**TEMPERATURE:** -40F TO 180F  
**PRESSURE:** VACUUM TO 200 PSI.  
**FLOW:** 2.2 Cv  
**FINISH:** ANODIZED BLACK  
**REPAIR KIT SPOOL #** 90A20388

**PROPRIETARY AND CONFIDENTIAL**  
 THE INFORMATION CONTAINED IN THIS DRAWING IS THE SOLE PROPERTY OF ALKON CORPORATION. ANY REPRODUCTION IN PART OR AS A WHOLE WITHOUT THE WRITTEN PERMISSION OF ALKON CORPORATION IS PROHIBITED.

DIMENSIONS ARE IN INCHES	
TOLERANCES:	
FRACTIONAL ±.010	
ANGULAR: MACH ± 1/2° BEND ±	
TWO PLACE DECIMAL ±.010	
THREE PLACE DECIMAL ±.005	
MATERIAL	--
RM. No.:	--
NEXT ASSY	USED ON
APPLICATION	DO NOT SCALE DRAWING

NAME	DATE
DRAWN WM	08/20/10
CHECKED --	--
ENG APPR.	
MFG APPR.	
Q.A.	
FINISH	

**ALKON CORPORATION**  
 FREMONT, OHIO

**3-WAY, Push/Pull, 3 Position Blocked Center Valve, Detented, 3/8" Ports**

SIZE <b>A</b>	DWG. NO. <b>TD-6600</b>	REV. <b>A</b>
SCALE: 1:2	WEIGHT: -	SHEET 1 OF 1